

# USING DESIGN AUTOMATION TO REDUCE COSTS, INCREASE PROFITABILITY

## Overview

By implementing design automation, engineer-to-order manufacturers can complete days of custom engineering in just minutes. Design automation also expedites and simplifies the creation of SolidWorks® software models, drawings, quote documents, manufacturing data—virtually any requirement of the custom sales process.

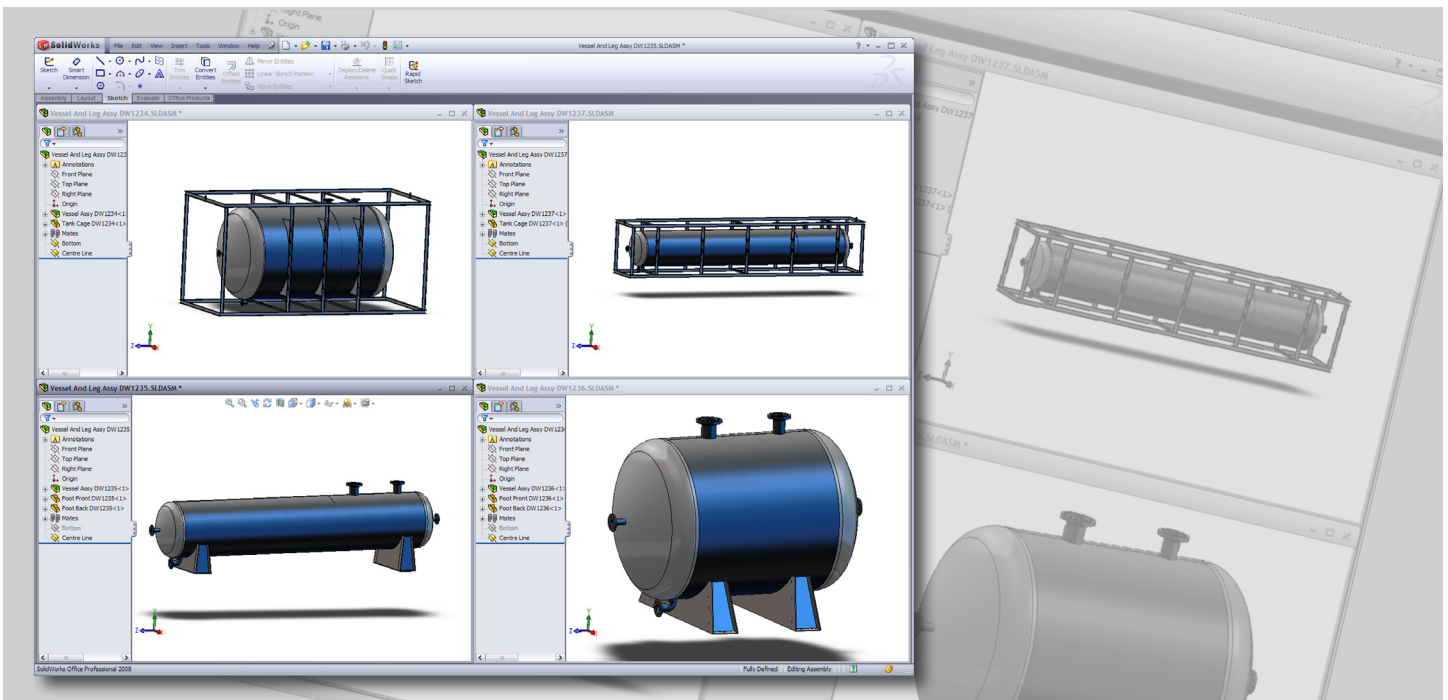

## Introduction

Across most industries today, profit margins are narrow and will continue to become even thinner. Even in segments where margins are relatively healthy, competition and global outsourcing make cost reduction mandatory. Historically, the high cost of engineering has contributed so significantly to the attack on profit margins, that numerous attempts have been made to cut the process time or the cost of engineering activities. Most of these approaches have been point solutions, which can be highly important in their own right, but are not applicable across the board. Design automation, on the other hand, stands out as an effective means of dramatically cutting costs for a well-defined, well-proven range of engineering activities. This is especially so where business needs demand rapid, accurate quoting; consistent engineering; and, most important, minimum time to finished product delivery.

### Driving design automation

The majority of companies share a common goal of reducing design costs. Traditionally, they have had two options: (1) to design less and standardize the product range, or (2) to design faster.

If you want to limit your customers' choices, the first option is fine. However, the pressure to customize products has risen tremendously over the past few years. In a recent Cincom study, 73 percent of total respondents viewed product customization as critical for products over \$100,000, while another 25 percent considered it crucial even for products under \$1,000.

This trend will only grow. The Cincom study revealed that 63 percent of engineers have seen requests for customized products increase over the last five years, and 26 percent anticipate that the growth rate will be between 25 and 50 percent in the next two years.

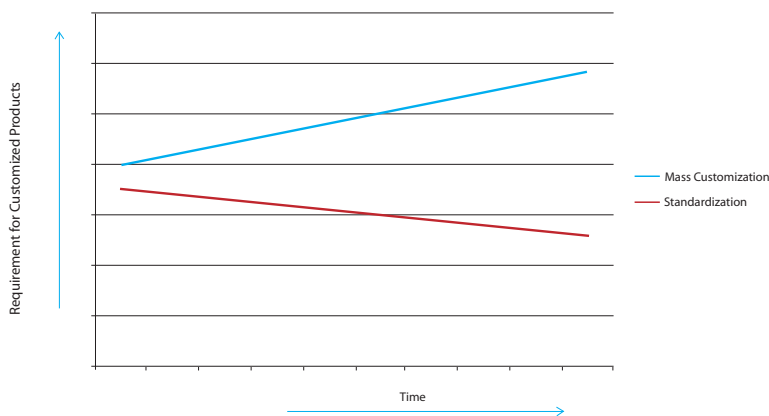

If you want to keep customers happy and grow your profit margins, the second option is ideal. Along with growth, however, come growing pains, especially if your custom design process is unmanaged.

"Because we are always fire-fighting, I often have to use out-of-date drawings just to get the job moving. This can lead to huge mistakes."

"We cannot quote quickly enough."

## More growth, more pain

Here are typical complaints that we commonly hear from companies that do not automate their design process:

“Because we are always fire-fighting, I often have to use out-of-date drawings just to get the job moving. This can lead to huge mistakes. From receipt of the order, we usually have six weeks to get the job out the door. Unfortunately, we generally don’t even get the drawings until after five weeks.”

“We simply cannot quote quickly enough. In fact, we reject small inquiries—around 30 percent of possible orders. We also rule ourselves out of a further 30 percent of possible contracts by missing quote submission dates.”

“Our sales people are forever selling things we can’t make... or they sell things that we can’t make at the price they quote to the customer.”

Design automation is the solution to the problems cited above—it provides rapid engineering as well as fast drawing and document production.

Another survey of CAD users asked key questions about the users’ design processes. All survey respondents were aware of design automation since they work in various industry segments that document paybacks from design automation. These include almost all engineer-to-order products and many custom or customizable products—basically, any enterprise whose product must be touched by engineering for a significant percentage of orders.

The primary single determinant of whether design automation will benefit a company or a designer is the extent to which new products are based on previous designs. Nearly two-thirds of respondents indicated that a significant portion of their products—from 20 to 100 percent—are so derived (Figure 1).

Two-thirds of companies using CAD derive all or part of their new designs from previous designs.

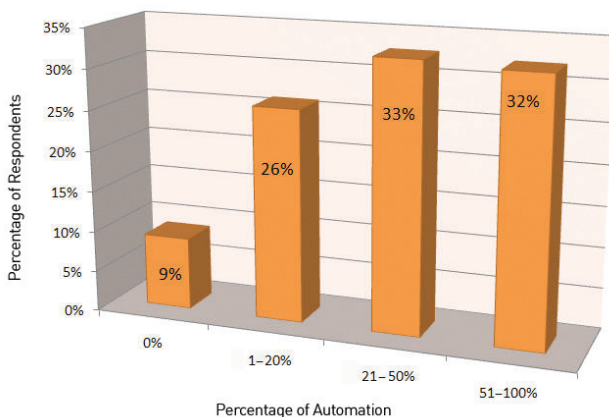

Figure 1: Many designs are based on previous designs, which are good candidates for design automation.

The survey concentrated on areas where design automation can contribute significantly, and prioritized its results into the following wish list for automating engineering activities:

- Automated creation of SolidWorks software parts, assemblies, and drawings based on variations of existing products (88.8%)
- Automatic generation of manufacturing documents (75.9%)
- Automatic retrieval and incorporation of existing product data and calculations (61.8%)
- Automatic generation of sales proposals, quotes, and documents (51.8%)
- Automated product specification by nontechnical associates, such as sales (45.3%)
- Automated, web-based product specification, such as remote sales or customers (30.6%)

---

Nearly 90 percent could benefit from automatic creation of SolidWorks software parts, assemblies, and drawings.

Clearly, everyone wants some sort of design automation—but the definition of design automation differs from company to company. Exactly what is design automation?

A variety of companies across a multitude of industries are searching for ways to save time and lower costs in the engineering process. As a result, various vendors refer to different features or utilities as “design automation.” Unfortunately, most of these are not useful mechanisms for automation because they cannot handle the entire job.

For companies that offer engineer-to-order products, design automation is specifically defined as a system that captures and more or less automatically applies that engineering activity to product variants resulting in finished designs in minimum time.

- **System:** a controller—rather than a random assortment of features—that provides an overarching workflow. Design automation systems often drive CAD systems and interact automatically with product lifecycle management (PLM), as well as with other engineering and office applications.
- **Engineering activity:** all the calculations, rules of thumb, engineering precepts, and product lore that go into a product variant.
- **More or less automatic:** intelligent design automation systems automate some things, usually repetitive or donkey work, and keep their hands off others, generally areas where experienced engineers can quickly assess a design requirement and rapidly supply a creative solution.
- **Product variants:** families of products derived from a central or standard design that must be touched significantly by engineering before full product functionality can be gained.

From an engineering perspective, you can overcome the difficulties encountered in customizing a product by using design automation software. This type of software evolved with CAD technology as a way to streamline customized product development. The idea is to capture a company's in-house design rules and thereby simplify the creation of variations on a theme.

Design automation does repetitive engineering tasks quickly, rolls up costs for accurate bids, and enforces engineering decisions that prevent sales from specifying noncompliant or unmanufacturable products.

Consider a typical conveyor design, for example. A number of factors affect the design, including space constraints; the weight, size, and spacing of products to be conveyed; belt or link type; and drive system.

Nontechnical people may think it is easy to take a base conveyor design, perhaps done for a recent installation, and rework a few details into a new conveyor for the next customer. Engineers know better, however. Once product weight and size vary in relation to the original design, any number of calculations will be required to give the new system its needed speeds and throughputs. If the original conveyor is for laundry detergents and the new one is for food products, regulatory requirements will mandate different materials and contamination control safeguards. A wider conveyor carrying heavier products will need more power, while a narrower one will almost certainly be more cost-effective with a smaller motor and gear train. If needed, more power will require significant changes in the geometry of the drive and motor installation. Guards, fences, and sensors will certainly be altered, possibly along with corresponding changes in frames, mounts, and metal gauges. No wonder it can take an average conveyor vendor's engineering department four to eight weeks to configure a new conveyor system manually.

---

Design automation addresses the "points of pain."

### **Is design automation effective and efficient?**

Design automation systems have been in use since the early 1980s, helping companies to save time and money. Recently, a machine builder accomplished all the engineering that once took 80 hours in less than one hour by implementing design automation. Within 24 hours, an elevator manufacturer can now create quotes and drawings, including engineering and documentation, which once took weeks with manual methods. A lifting beam company can respond to customer enquiries with general arrangement drawings and a quotation in less than an hour—deliverables that previously took 16 hours.

Even small products benefit—component brackets that took 45 minutes to configure manually at one company are now done in less than one minute.

So, yes, design automation is both effective and efficient.

The good news is that design automation is available to every SolidWorks software user through DriveWorksXpress, which is included in every single seat of SolidWorks 3D CAD software.

## Do configurators perform design automation?

Many configurators state that they do perform design automation tasks, and countless demos confirm this. However, most are just an afterthought rather than the core competency of the system. Invariably, design automation is served via programming-based customization.

Configurators typically mix and match rather than engineer. That is, they can add and remove items on bills of materials (BOMs), but cannot understand the types of calculations required for engineering or the workflow of engineering. As a result, most configurators simply cannot handle engineer-to-order designs.

Design engineers require a system that will drive the CAD package in a coherent and controlled manner. Moreover, every point of automation must be done consistently, with nothing forgotten, nothing fudged—and everything completed.

### Table 1. The benefits of design automation

In the table below, the key benefits of design automation are reflected by organizational level.

ORGANIZATIONAL LEVEL	BENEFITS
Engineer	<ul style="list-style-type: none"><li>• Greatly reduces sales support requirements</li><li>• Dramatically reduces repetitive tasks</li></ul>
Engineering Department	<ul style="list-style-type: none"><li>• Significantly increases departmental productivity and throughput</li><li>• Greatly improves consistency, especially with junior engineers</li><li>• Quickly enables first-to-bid on quotes</li></ul>
Company	<ul style="list-style-type: none"><li>• Easily helps to ensure accurate bid and product costing for predictable margins</li><li>• Dramatically shortens time-to-delivery after order is signed</li><li>• Readily helps develop true teamwork between engineering and sales</li></ul>

Table 1: Design automation frees up engineering time formerly given to repetitive tasks, recalculation, and specification changes. The resulting benefits apply across the organization, from the individual engineer to the company as a whole.

## Design automation in practice

Design automation should be viewed as a new way of working, not as a single project with a beginning and an end that is only done once. With design automation, you can literally treat every part of an assembly as a variable design that can be automatically modified by inputs. Doing so, however, would be a mistake. Your first step is to determine which variable parts require engineering while they are being varied, and which will generally be a subset of a given assembly. Then select a best candidate from among these to tackle the first design, which is typically a redesign that literally takes more time than it is worth.

Consider our conveyor illustration as an example. Most conveyors consist of a frame, legs, rollers or bearings, and links or belts. One or more sides require guards and fences. Some consist of straight sections with minimum change in elevation, while others spiral up or down significant vertical distances. There are control and sensor needs, drive and gearing considerations, as well as various other components that will be modified to meet a specific custom requirement.

Since numerous variables exist, it would be naïve to imagine that you could put all of the details about all of these parts into your rules-based system in one go. Where would you start? What route would you follow? Answer that, and you have the answer to the initially underconstrained task. The key, of course, is to build your automated activities one step at a time.

### Build one element at a time

Start by automating individual elements. You do not have to start from scratch, however. Since DriveWorksXpress allows you to adopt existing SolidWorks software assemblies, you can add rules and make them intelligent. With the conveyor system, for example, you could begin with a single series of drive and gear designs. In design automation, you can easily create a system whose outputs include dramatically different geometries and configurations based on such specifications as product weight, pitch, and conveyor width. You could then create a rule that takes a specified number of drive systems for a given length of conveyor. From there, you can build rules that will automate the design of idle rollers, then frame components, and so on.

Before long, you will achieve a conveyor-generating system that performs design automation. After you specify the size and weight of the product along with the system dimensions, DriveWorksXpress will calculate the frame design, populate it with drives and idlers, and automatically generate the chains or belts. From there, you can add capabilities to create the drawings, documents, and data for conveyor systems, which will be useful first in sales quotations and later in manufacturing documents.

---

Design automation is a new way of working. It is not a one-off.

---

Start small—and adopt existing SolidWorks software models.

## Creating the rules

Attaching the rules to the basic design is a straightforward way to select the SolidWorks software model, and then follow the DriveWorksXpress interface as it walks you through the process (Figure 2). The DriveWorksXpress interface enforces a consistent workflow, allowing you to easily attach variables and parameters, engineering rules, and myriad engineering-related activities to the design. In the background, DriveWorksXpress manages all the relationships between rules and assemblies, as well as the necessary interconnectivity between the DriveWorksXpress model and the entities within SolidWorksXpress.

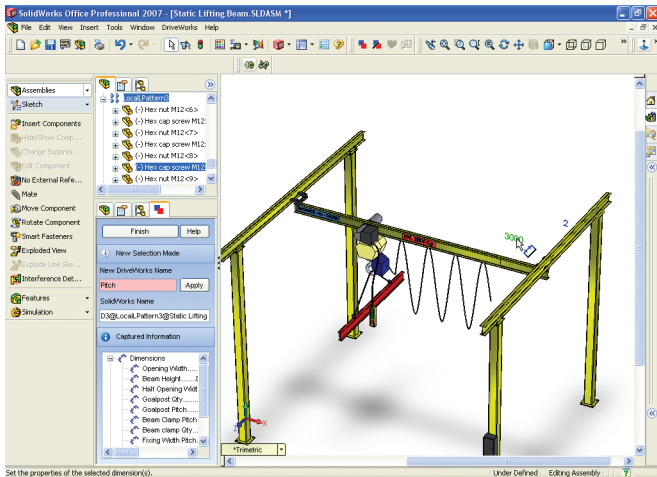

Figure 2: In this example of a gantry crane, the DriveWorksXpress interface walks the user through the process of attaching dimensions, properties, and rules to a given assembly.

As you add rules for the legs, beam, and motor into DriveWorksXpress, it becomes a step-by-step process. Eventually, you will build a complete model; by doing it in steps, however, you can gain benefits along every step of the way. For many projects, you will find it best to maintain a top-down view while working in a bottom-up manner. A little thought will allow you to reinvest a good deal of the time spent in building one model when you turn to creating the next one.

Clearly, rules-based design automation systems capture the way you engineer, allowing the computer to do much of the recalculations and the remodeling that take up so much of your time. These systems can also manage and retrieve a broad range of design methods and criteria built up by your company, including important engineering rules, rules of thumb, and product lore that, if forgotten or ignored, can lead to product problems and unhappy customers.



## Key evaluation criteria

Engineers choose SolidWorks software for its powerful modeling and revolutionary interface. When you are searching for the ideal design automation model, you want the same dynamic combination. Unfortunately, it is not included in all design automation packages.

In fact, you will find that design automation business models range from ones that dictate buying software and consulting, to the DriveWorkXspress model which is easily installable software that allows you to build your own rules, calculations, and models quickly. After all, since you bring product knowledge and expertise to the table, you should retain complete control over that intellectual property.

Solutions that require consulting harken back to the first days of design automation. In the early 1980s, engineering design was far different than it is today. Affordable CAD software that ran on small computers was 2D and not graphical in its interface. Serious 3D design required minicomputers and high-end CAD, and generally mandated specialized consulting for installation and startup. A CAD system that cost \$40,000 per seat in 1985 dollars for basic 3D capability could easily demand \$100,000 in consulting—and \$140,000 in 1985 is the equivalent of nearly \$275,000 today. Then and now, that is an investment only large companies could make.

During this time, the early design automation products presented two major obstacles—their price, easily \$1 million (\$1.9 million today), and their inability to interoperate with the CAD systems of the day. The geometry and spatial relationships of every part, no matter how complete in a given company's CAD system, had to be completely rebuilt in the design automation system. Furthermore, the process required the mastery of an arcane coding language. No wonder consultants were needed.

In the same way that 3D CAD has become mainstream, modern design automation also offers a mainstream choice. Unfortunately, a number of design automation systems still follow the old mold, possibly because the original model still appeals to system designers. If you are considering a system that requires third-party coding and handholding—an outdated modality that SolidWorks software moved beyond over a decade ago—then you should move beyond it as well.

Aside from the business model, you should consider the following criteria when selecting a design automation system:

1. Ease of use
2. Maintainability
3. Scalability
4. System integration

---

Look for a 21st-century system—not one saddled with implementation models from the 1980s.

## **Ease of use**

When companies consider whether to adopt design automation, ease of use is the number one concern. After all, who wants to invest time and money in a system that is so difficult to set up and implement that no one will use it? Engineers need a system that runs on hardware everyone can understand—one that is built on a development platform with a proven track record. A system equipped with user interface and integration capabilities allows you to interoperate with other software systems as well.

To capture engineering rules, your system must use current engineering skills, rather than require engineers to become programmers, system integrators, or IT specialists.

## **Maintainability**

The second criterion is maintainability. At most companies, the introduction of a design automation system is generally driven by one or more champions who can see the personal and company benefits of adopting this technology. However, there comes a time in a successful implementation when the system must move beyond the original champions. For this, you need a system that can be understood by many and easily maintained by all.

When choosing a system, consider the following questions:

- What will happen when a key member of your design team joins another company, or if a highly experienced and valuable team member retires?
- When your organization introduces a new operating system, what will take place?
- What will occur when you introduce new hardware?
- Will the design automation system always work with the latest CAD version, or will there be a time lag?
- When your design teams want to communicate and collaborate across continents, what will be the result?

No matter what changes take place, you must be able to ensure that any project will continue.

Not only must your system be capable of working with mainstream operating systems, but it must also be compatible with the latest versions of your CAD software. Additionally, the system should enable you to document the details of the rules being used, and also present a clear picture of how they fire, relate, and affect each other.

## Scalability

Is the solution scalable? That is, can you start small and easily ramp up to a complete system? Can you expand small automation projects based on highly constrained assemblies into more comprehensive systems?

In practice, the implementation of design automation has no beginning or end. A successful system depends on an approach that allows you to create and refine a process that grows over time—one that automates more and more aspects of your design and engineering, while delivering more and more benefits to your organization.

If the company's design automation system provides no easy path to the next component for automation, life becomes difficult. That is why you must be assured that the next step, the step after that, and all the steps into the future can be easily married to the original project.

## System integration

Design automation generally begins in the engineering department. However, every company function that interfaces with engineering can eventually benefit from design automation. To offer all the benefits, your design automation system must be capable of integrating with other business systems.

In an ideal world, many companies look for seamless integration among all their systems. They do not want duplication of effort, and most have discovered the pain of maintaining several separate customer databases run by different departments. Therefore, when selecting a system, you should specify a design automation system that is capable of interoperability with broader business systems.

## Return on investment

No software purchase would be complete without a consideration of return on investment (ROI). The ROI of a design automation system depends on a number of factors, including some of the criteria discussed above. Clearly, a key consideration is the length of time it takes to begin using design automation in production.

With generic software, the critical element is how easy it is to install and use. Here, you must factor in the training and the skill sets required by the people who will be using it. A system that never reaches beyond a few outstanding, highly trained engineers is never going to provide the highest possible ROI. Likewise, a system that requires a dedicated programmer or ongoing help from consultants is unlikely to reach mainstream paybacks.

Finally, there is the question of how soon you will begin realizing returns. To a large extent, this depends on how you set your objectives and measure success. A custom or consultant-based solution can take many months before product specifications can be entered into the system and outputs automatically generated. Further, companies often make the mistake of striving for a total solution right from the start. Having to depend on completing every aspect of a design automation project before putting it to real work is highly detrimental to ROI.

---

Prepare for growth—make it scalable.

## Conclusion

Consider again our conveyor system. It might take two days to put the rules that automate the selection of motors and gears, as well as the subsequent geometry of the assembly, into DriveWorksXpress. However, you could automate the design of all future conveyor systems within a week, automatically generating manufacturing data, drawings, and BOMs—each based on inputs that reflect the requirements of each respective customer. So even if it takes twice as long to capture the process in DriveWorksXpress than it does to create a single custom design, by the third new order you will start to get tangible benefits.

With your purchase of SolidWorks 3D CAD software, you have DriveWorks capability built into your investment, as DriveWorksXpress is also included in your distribution media. By identifying a design, an assembly, a subassembly, or a part capable of automation, you will be taking your most important first step. Support documentation and extensive help files are on your distribution media. You can find more background and guidance from the DriveWorks website: <http://www.driveworks.co.uk>

Choose to design faster—and take your inspiration from the many companies who have successfully implemented design automation. It is a perfect means to raise your visibility in the company, increase your company's profitability on custom sales, and allow you to do what you do best—design innovative new products.

---

Dassault Systèmes  
SolidWorks Corp.  
300 Baker Avenue  
Concord, MA 01742 USA  
Phone: 1 800 693 9000  
Outside the US: +1 978 371 5011  
Email: [info@solidworks.com](mailto:info@solidworks.com)  
[www.solidworks.com](http://www.solidworks.com)

